

THE INFORMATION CONTAINED IN THIS DRAWING IS THE SOLE PROPERTY OF IOWA LASER TECHNOLOGY INC. ANY REPRODUCTION IN PART OR WHOLE WITHOUT THE WRITTEN PERMISSION OF IOWA LASER TECHNOLOGY INC. IS PROHIBITED.

REV.	DESCRIPTION	DATE	APPROVED
-	-	-	-
-	-	-	-
-	-	-	-

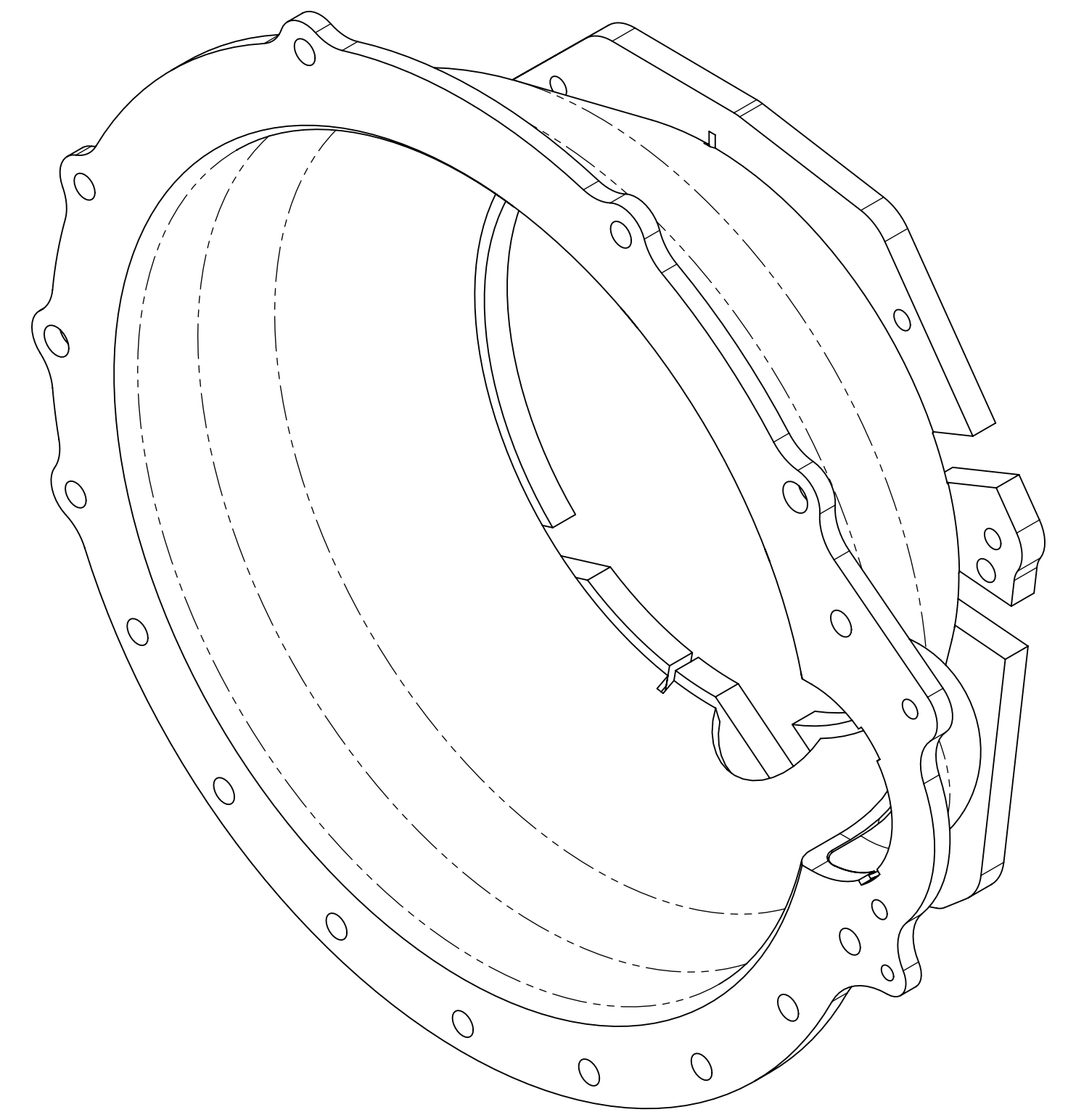
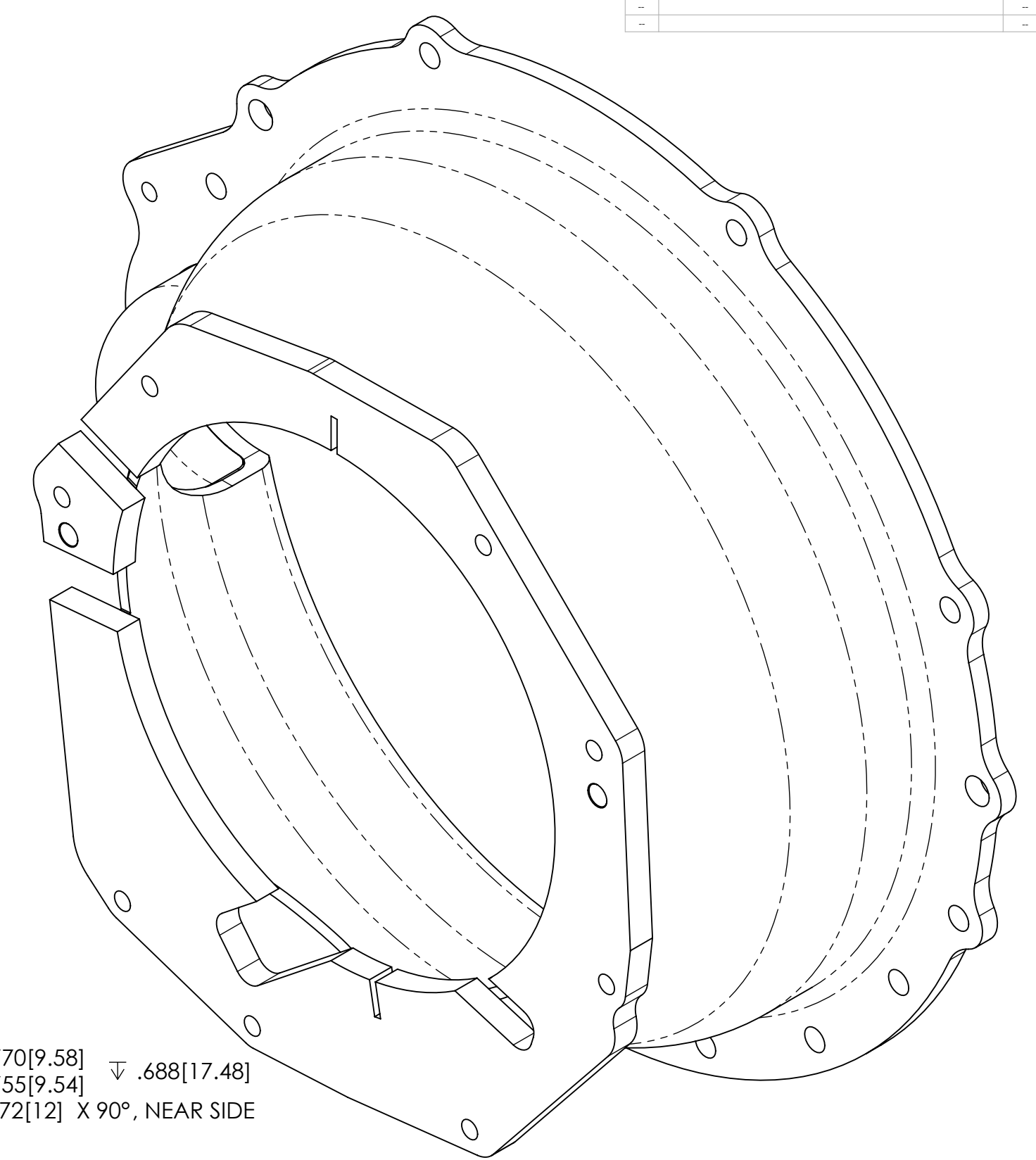
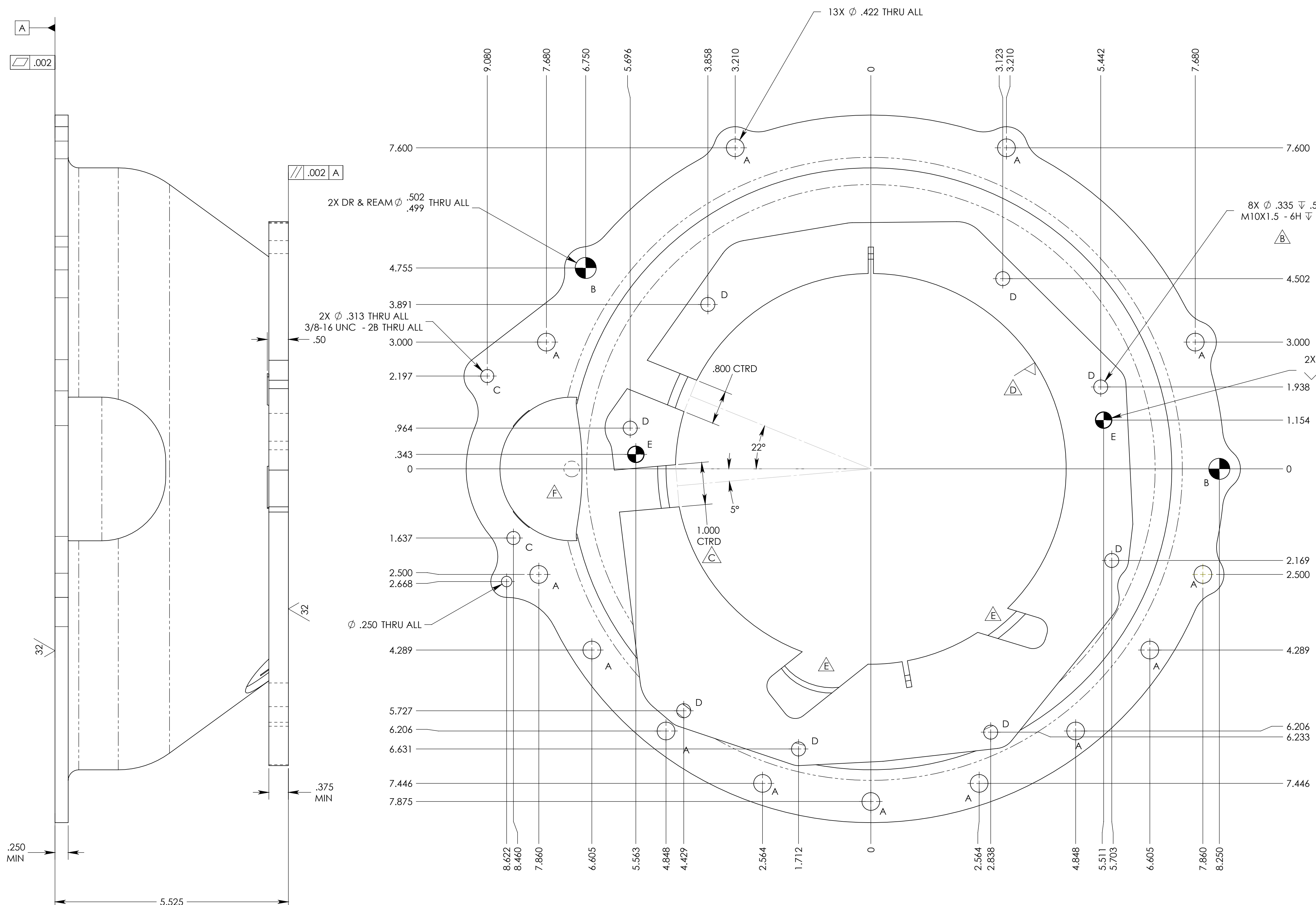

REVISIONS				
ZONE	REV.	DESCRIPTION	DATE	APPROVED
A	A	REVIEWED AND APPROVED	10/25/2007	ROSS MCCOMBS
	B	WAS 3/8-16 UNC	1/23/2008	
	C	WAS .50 CTRD	2/28/2008	
	D	ADDED FINISH MARK	7/8/2008	
	E	ADDED RELIEF CUTS TO TRANNI PLATE	5/13/2009	
	F	ADDED STARTER POCKET COVER	6/12/2009	

IOWA LASER TECHNOLOGY INC.
 7100 CHANCELLOR DR.
 CEDAR FALLS, IA 50613
 PHONE: 319-266-3561
 FAX: 319-266-8203

UNLESS OTHERWISE SPECIFIED DIMENSIONS ARE IN INCHES TOLERANCES ARE:		CAD GENERATED DRAWING. DO NOT MANUALLY UPDATE		PARTS LIST	
FRACTIONS	DECIMALS	ANGLES	APPROVALS	DATE	CUSTOMER:
±1/16	±.005	±1°	STW	Tuesday, October 23, 2007 11:11:07 AM	QUICKTIME
±.005	±.005	±1°	CHECKED BY:		JOB / GROUP NAME: MOPAR BB (383/400/440) TO T56 CHEVY
			APPROVED BY:		DRAWING TITLE: BELL HOUSING
FORMED PARTS ±.030 PER BEND			LAST EDIT DATE	Monday, September 21, 2009 8:12:53 AM	CAD FILE: L:\SW\QuickTime\RM-6077
DO NOT SCALE DRAWING					SCALE: 3:4 DWG. NO.: RM-6077

THE INFORMATION CONTAINED IN THIS DRAWING IS THE SOLE PROPERTY OF IOWA LASER TECHNOLOGY INC. ANY REPRODUCTION IN PART OR WHOLE WITHOUT THE WRITTEN PERMISSION OF IOWA LASER TECHNOLOGY INC. IS PROHIBITED.

REVISIONS			
REV.	DESCRIPTION	DATE	APPROVED
-	-	-	-
-	-	-	-
-	-	-	-

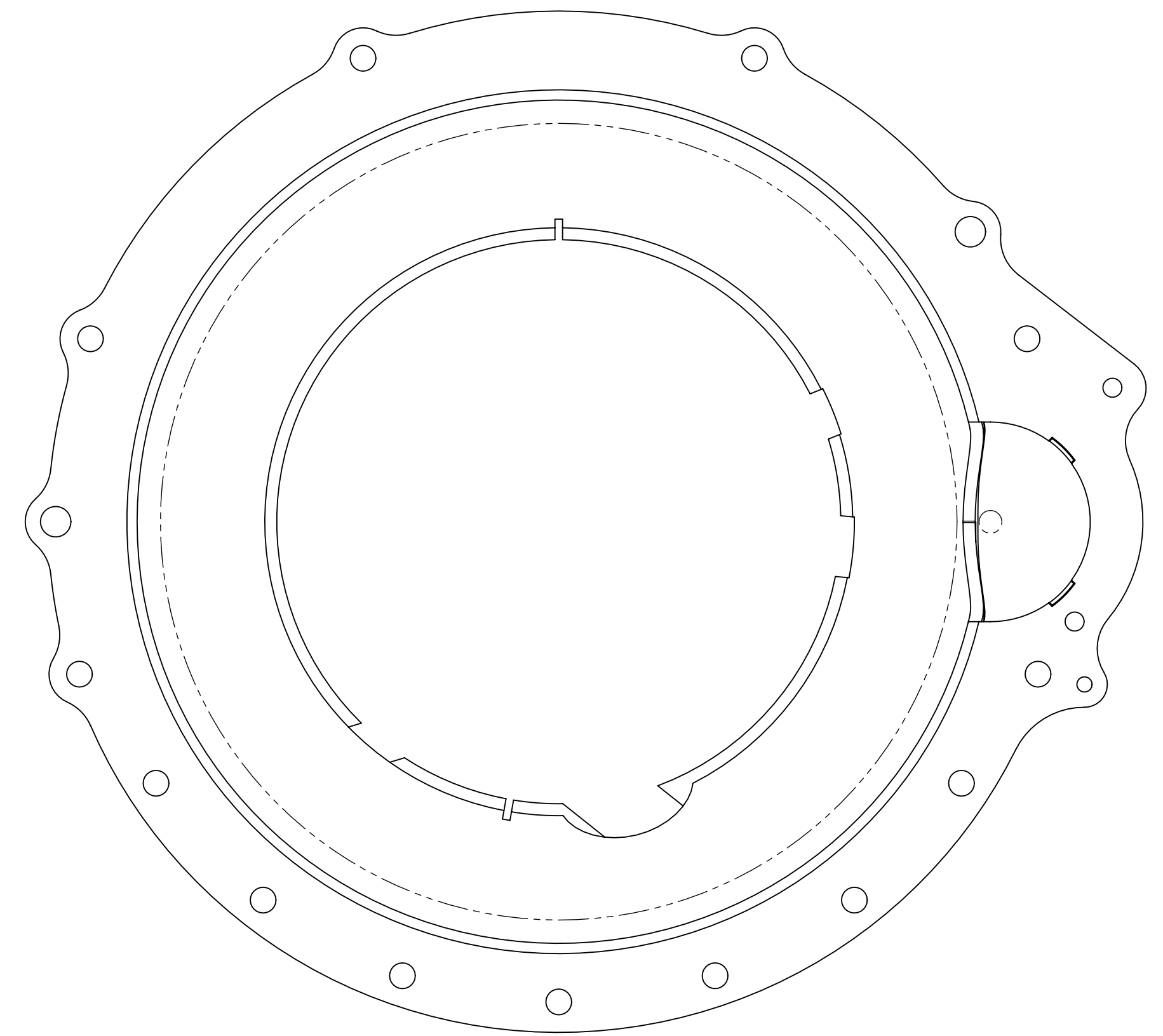
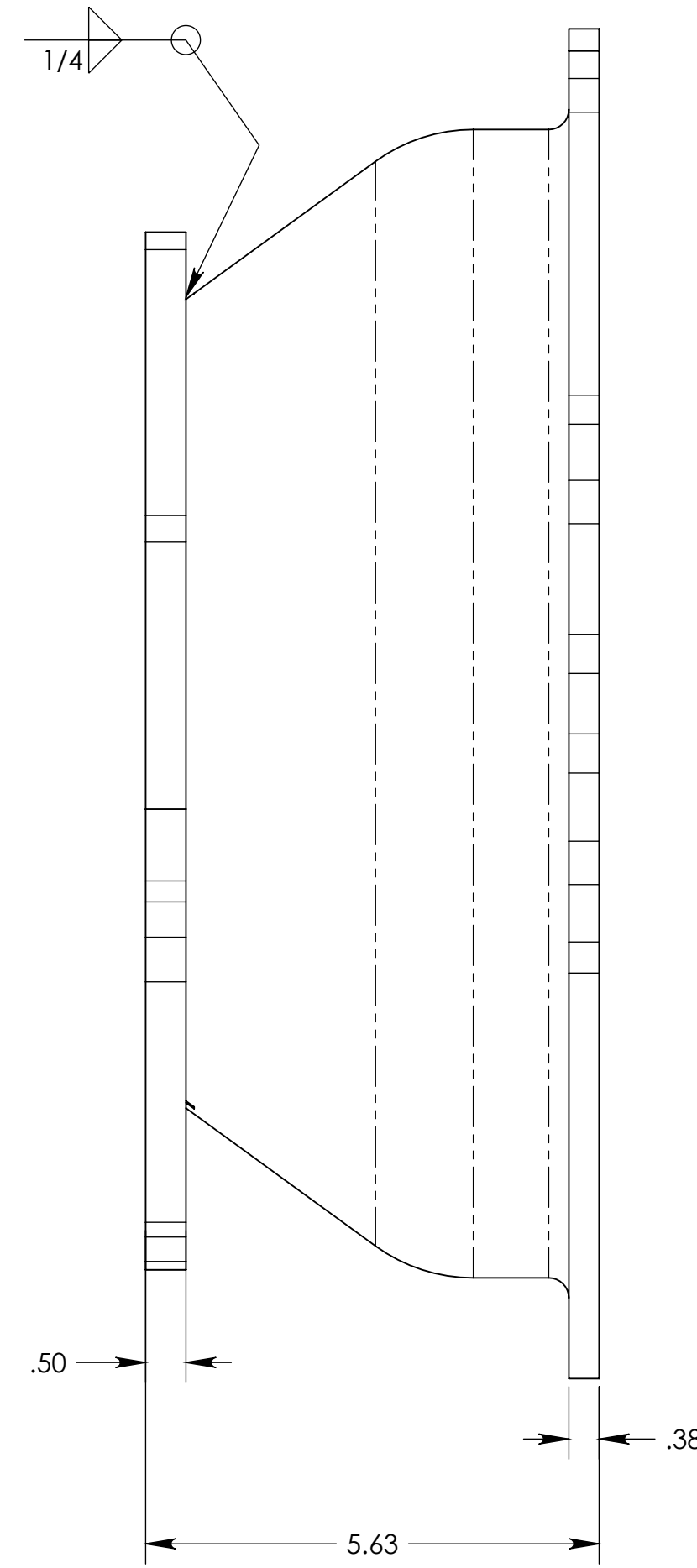
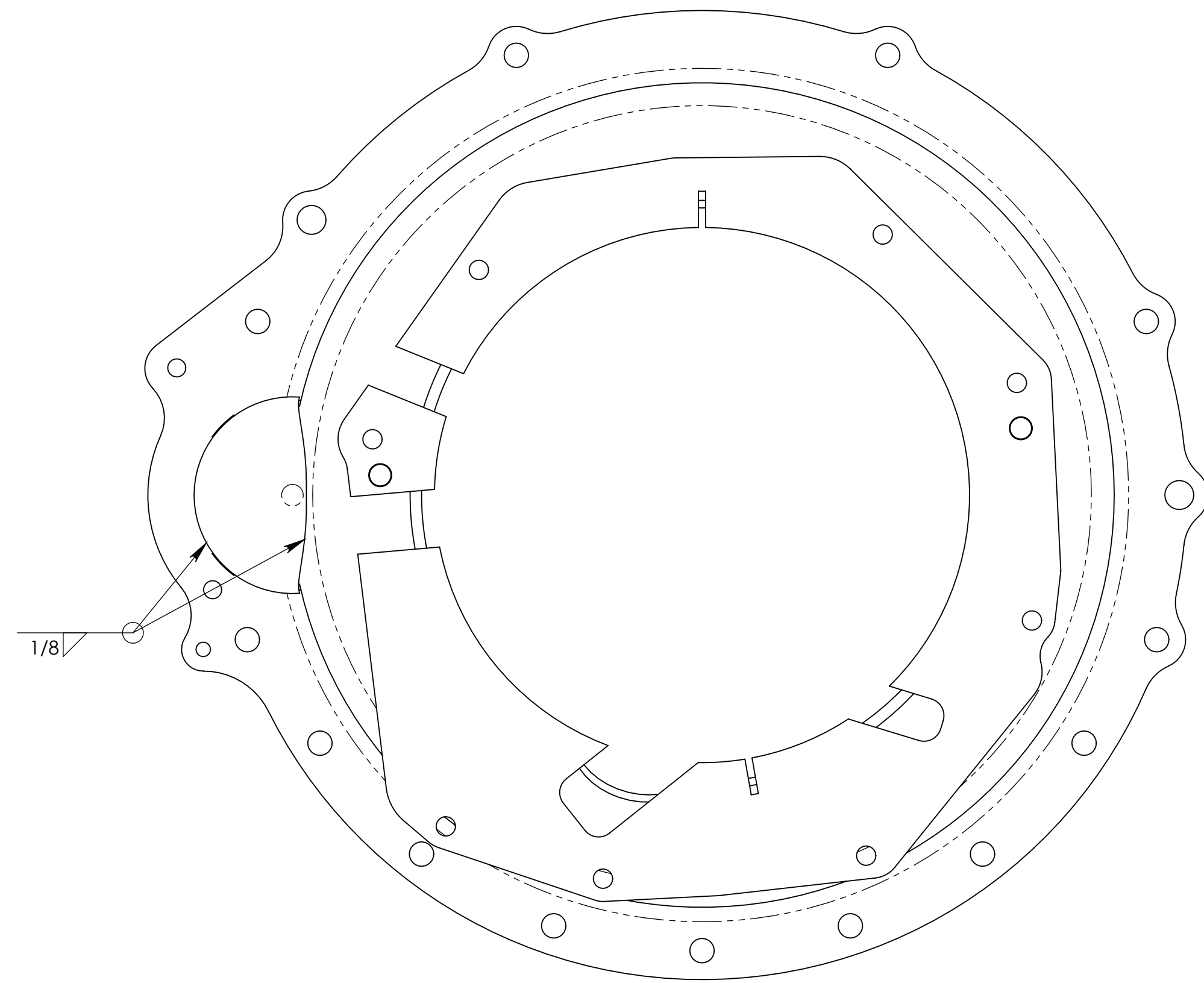

IOWA LASER TECHNOLOGY INC.
 7100 CHANCELLOR DR.
 CEDAR FALLS, IA 50613
 PHONE: 319-266-3561
 FAX: 319-266-8203

UNLESS OTHERWISE SPECIFIED DIMENSIONS ARE IN INCHES TOLERANCES ARE:		C/D GENERATED DRAWING. DO NOT MANUALLY UPDATE		PARTS LIST	
FRACTIONS	DECIMALS	ANGLES	APPROVALS	DATE	CUSTOMER:
±1/16	.X ±.03	±1°	STM	Tuesday, October 23, 2007 11:11:07 AM	QUICKTIME
	.XXX ±.005		CHECKED BY:		JOB / GROUP NAME:
			---		MOPAR BB (383/400/440) TO T56 CHEVY
FORMED PARTS ±.020 PER BEND			APPROVED BY:		DRAWING TITLE:
			---		BELL HOUSING
MASS			LAST EDIT DATE	Monday, September 21, 2009 8:12:53 AM	CAD FILE:
---					L:\SW\QuickTime\RM-6077
DO NOT SCALE DRAWING					SEE
					D
					SCALE
					1:2
					DWG. NO.
					RM-6077
					REV.
					F